

Patch Antenna in Isotropic Plasma: Resonant Frequency

S.K. Dash, A. Patnaik, G.K. Patro and R.K. Mishra
 Berhampur University-760 007.

ABSTRACT

A method has been developed to compute the resonant frequency of a rectangular microstrip antenna immersed in a linear isotropic plasma medium using Wolf's dynamic dielectric constant model. The results obtained are in agreement with those obtained using spectral domain technique. It has been observed that the antenna resonates at a higher frequency inside the plasma than in free space.

1. INTRODUCTION

Microstrip antennas are capable of low profile mounting on the aft-end of re-entering vehicles¹. During the voyage of such vehicles, the mounted antenna encounters plasma medium. It is shown in this communication that when the antenna encounters plasma medium, its resonant frequency changes from that in the free-space medium. Results obtained using the theory developed have been compared with those obtained by spectral domain immittance (SDI) analysis.

2. THEORY

The resonant frequency of a rectangular microstrip antenna of length L and width W radiating into free-space surroundings is given² by

$$f_o = \frac{V_o}{2\sqrt{\epsilon_{dyn}}} \left[\left(\frac{m}{W} \right)^2 + \left(\frac{n}{L} \right)^2 \right]^{1/2} \quad (1)$$

where

$$\epsilon_{dyn} = \frac{C_{dyn}(\epsilon = \epsilon_o \epsilon_r)}{C_{dyn}(\epsilon = \epsilon_o)} \quad (2)$$

= A function of dimensions of the antenna.

$C_{dyn}(\epsilon = \epsilon_o \epsilon_r)$ = Dynamic capacitance between the patch and ground plane, when the substrate dielectric constant is ϵ_r .

$C_{dyn}(\epsilon = \epsilon_o)$ = Dynamic capacitance, when the space between the patch and the ground plane is free-space

V_o = Speed of electromagnetic wave in free-space

m and n = Mode numbers.

For the antenna immersed in plasma, $C_{dyn}(\epsilon = \epsilon_o)$ is replaced by $C_{dynp}(\epsilon = \epsilon_o \epsilon_p)$, which is the dynamic capacitance, when the space between the patch and the ground plane is filled with plasma having dielectric constant

$$\epsilon_p = 1 - \frac{f_p^2}{f_r^2} \quad (3)$$

f_p = Plasma frequency

f_r = Resonant frequency of the antenna in plasma medium.

Thus, Eqn (2) is modified as

$$\epsilon_{pdyn} = \frac{C_{dyn}(\epsilon = \epsilon_o \epsilon_r)}{C_{dynp}(\epsilon = \epsilon_o \epsilon_p)} \quad (4)$$

$$= \frac{C_{dyn d}(\epsilon = \epsilon_o \epsilon_r) / C_{dyn}(\epsilon = \epsilon_o)}{C_{dyn p}(\epsilon = \epsilon_o \epsilon_p) / C_{dyn}(\epsilon = \epsilon_o)} = \frac{\epsilon_{dyn}}{\epsilon_{dyn p}} \quad (5)$$

where

$$\epsilon_{dyn p} = \frac{C_{dyn p}(\epsilon = \epsilon_o \epsilon_p)}{C_{dyn}(\epsilon = \epsilon_o)}$$

is the dynamic dielectric constant of the microstrip line radiating into free-space surroundings, when the space between the patch and the ground plane is filled with plasma. Following Wolf's procedure, the dynamic dielectric constant are

$$C_{dyn}(\epsilon_o \epsilon_x) = C_{o, dyn} + 2C_{eL, dyn} + 2C_{eW, dyn} \quad (6)$$

$$C_{o, dyn} = \frac{C_{o, stat}}{\delta_m \delta_n} = \frac{\epsilon_o \epsilon_x L W}{h \delta_m \delta_n} \quad (7)$$

$$C_{eL, dyn} = \frac{1}{\delta_n} C_{eL, stat} \quad (8)$$

$$C_{eW, dyn} = \frac{1}{\delta_m} C_{eW, stat} \quad (9)$$

$$\delta = \begin{cases} 1 & \text{if } p = 0 \\ 2 & \text{otherwise} \end{cases}$$

$$C_{eL, stat} = \frac{1}{2} \left[\frac{1}{v_{pL} Z(W, h, \epsilon_x)} - \frac{\epsilon_o \epsilon_x W}{h} \right] L \quad (10)$$

$$C_{eW, stat} = \frac{1}{2} \left[\frac{1}{v_{pW} Z(L, h, \epsilon_x)} - \frac{\epsilon_o \epsilon_x L}{h} \right] W \quad (11)$$

$$v_{pL} = \frac{V_o Z(W, h, \epsilon_x)}{Z(W, h, \epsilon_x=1)} \text{ and } v_{pW} = \frac{V_o Z(L, h, \epsilon_x)}{Z(L, h, \epsilon_x=1)} \quad (12)$$

$$Z(Y, h, \epsilon_x) = \frac{120 \pi}{\sqrt{\epsilon_{eff}(Y, \epsilon_x)}} \left[\frac{Y}{h} + 1.393 + 0.667 \ln \left(\frac{Y}{h} + 1.444 \right) \right]^{-1} \quad (13)$$

for $\frac{Y}{h} \geq 1$

$$\epsilon_{eff}(Y, \epsilon_x) = \frac{\epsilon_x + 1}{2} + \frac{|\epsilon_x - 1|}{2} \left(1 + \frac{10h}{Y} \right)^{-1/2}$$

The modulus is taken in Eqn (14) to ensure that (i) if $\epsilon_x > 1$, then $1 < \epsilon_{eff} < \epsilon_x$, (ii) if $\epsilon_x < 1$, then $\epsilon_x < \epsilon_{eff} < 1$

In Eqns (6) to (14), $\epsilon_x = \epsilon_r$ or ϵ_p , depending on the surroundings and $Y = L$ or W , depending on the direction of propagation in the microstrip line assuming the quasi-transverse electromagnetic mode.

As explained earlier, when the antenna is radiating into plasma, ϵ_{dyn} is to be replaced by $\epsilon_{p dyn}$ and thus Eqn (1) is modified as

$$f_r = \frac{V_o}{2\sqrt{\epsilon_{p dyn}}} \left[\left(\frac{m}{W_{eff}} \right)^2 + \left(\frac{n}{L_{eff}} \right)^2 \right]^{1/2} \quad (15)$$

where, following Garg and Long³, the effective length L_{eff} and the effective width W_{eff} can be obtained using the formula

$$L_{eff} = L + \frac{(W_{eq} - W) \epsilon_{ep}(W) + 0.3}{2 \epsilon_{ep}(W) - 0.258} \quad (16)$$

$$W_{eq} = \frac{120 \pi \times h}{Z(W, h, \epsilon_{ep}) \epsilon_{ep}(W)} \quad (17)$$

$$Z(W, h, \epsilon_p) = \frac{120 \pi}{\sqrt{\epsilon_p}} \left[W/h + 1.393 + 0.667 \ln(W/h + 1.444) \right]^{-1}$$

$$\epsilon_{ep}(W) = \frac{(\epsilon_r + \epsilon_p)}{2} + \frac{(\epsilon_r - \epsilon_p)}{2} \left[1 + \frac{10h}{W} \right]^{-1/2}$$

Similarly, W_{eff} can be obtained by interchanging L and W in Eqns (16) to (18).

The R.H.S. of Eqn (15) contains the terms $\epsilon_{p dyn}$, L_{eff} and W_{eff} , which are functions of ϵ_p . ϵ_p is a function of f_r [Eqn (3)]. Thus, the R.H.S. of

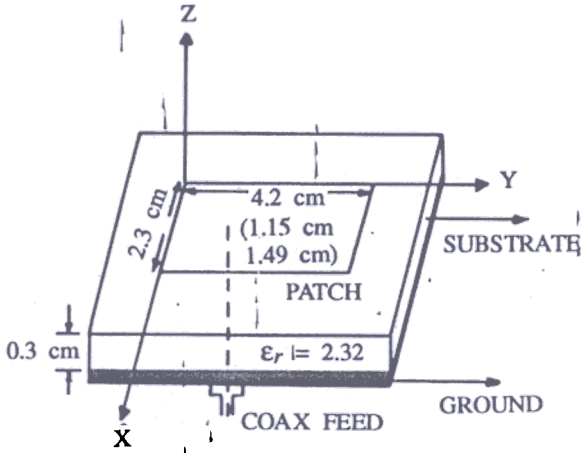

Figure 1. Patch antenna indicating dimensions

Eqn (15) is also a function of f_r and, therefore, can be expressed as

$$f_r = F(f_r) \quad (19)$$

with

$$F(f_r) = \frac{V_o}{2\sqrt{\epsilon_{pdy}}} \left[\left(\frac{m}{W_{eff}} \right)^2 + \left(\frac{n}{L_{eff}} \right)^2 \right]^{1/2} \quad (20)$$

Now Eqn (19) can be solved for f_r using standard numerical techniques.

3. RESULTS

Results for a rectangular patch antenna (Fig. 1) of length (L) = 4.2 cm and width (W) = 2.3 cm on a PTFE substrate ($\epsilon_r = 2.32$) of thickness (h) = 3 mm are provided here for its dominant transverse magnetic (TM_{01}) mode. The results obtained using the present technique and the SDI^{4,5} technique have been compared. It is very difficult to apply SDI technique to predict the resonant frequency of the patch antenna in a dispersive (plasma) medium. To avoid the mathematical and computational problems involved, an indirect method was adopted. Different ϵ_p values between 0 and 1 were taken. Then SDI technique was used to calculate the resonant frequencies for each value of these ϵ_p values. Then for each ϵ_p value, the plasma frequency was calculated from the corresponding resonant frequency using Eqn (3). Plasma

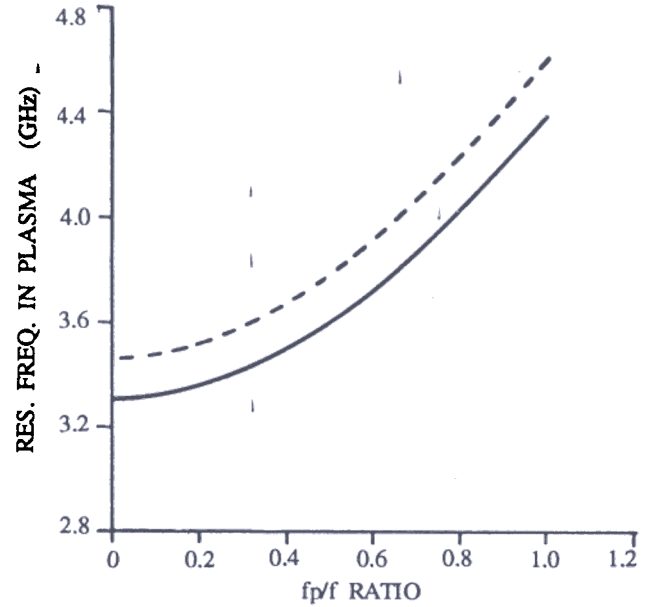

Figure 2. Variation of resonant frequency in plasma medium with f_p/f , where $L = 42$ mm, $W = 23$ mm, $h = 3$ mm, $\epsilon_r = 2.32$, $d = 1$ mm (feed prob. diameter).

frequencies obtained by the SDI technique in this process were then used to find the resonant frequencies of the antenna using the theory developed. A comparison between these resonant frequencies (solid line) with the resonant frequencies obtained using the SDI technique (dashed line) at different f_p/f values is made in Fig. 2. Both the curves follow each other very closely and the deviation between them is less than 0.5 per cent, which indicates higher accuracy of this method in comparison to the SDI technique. Figure 3 shows the variation of resonant frequency in dominant TM_{01} mode of patch antenna in plasma medium with the corresponding resonant frequency in free-space for different ϵ_p values. These curves are increasing monotonically, indicating that the antennas resonate at a higher frequency in plasma than in free-space. It is further observed that there is a nominal increase in resonant frequency with increase in ϵ_p value. Figure 4 is the curve indicating the variation in the resonant frequency of antennas in plasma medium with their aspect ratios for different patch widths. It is observed that the resonant frequency in plasma increases with increase in aspect ratio of the antenna. It is also

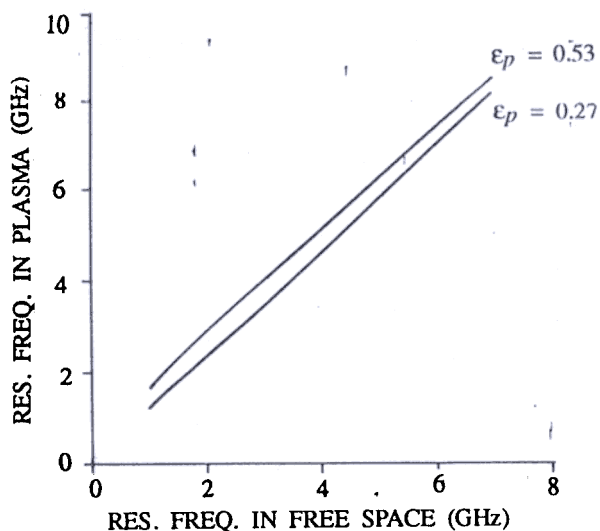

Figure 3. Comparison of resonant frequencies in plasma with that in free-space (L is varied, to vary the free-space resonant frequency).

observed that the resonant frequency in plasma increases (i) rapidly with decrease in L when W is kept constant, and (ii) slowly with decrease in W when L is kept constant.

4. CONCLUSION

It has been found that the proposed theory predicts resonant frequencies with a higher accuracy (99.5 per cent) in comparison to the SDI technique. It can also be inferred that there is a possibility of detuning of the antenna, as the re-entry vehicle carrying such an antenna enters into the ionosphere and gets surrounded by plasma. This detuning can result in a possible signal blackout, unless adequate precautions are taken.

ACKNOWLEDGEMENTS

The authors are thankful to the Department of Electronics, Government of India, for sanctioning this technology development project.

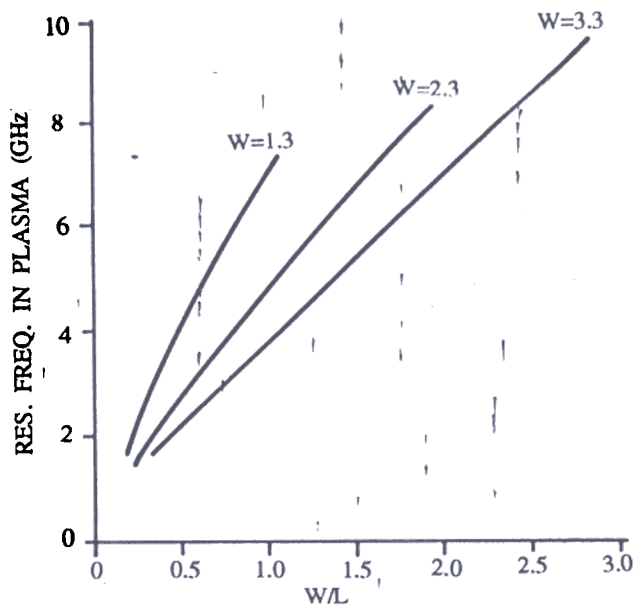

Figure 4. Plot of resonant frequency in plasma vs aspect ratio for different patch widths.

REFERENCES

- Patnaik, S.S.; Mishra, R.K. & Das, N. Microstrip antenna on a ferrite substrate in plasma medium. *Indian J. Radio Space Phy.*, 1991, 20, 417-19.
- Wolf, I. & Knoppik, N. Rectangular and circular microstrip disk capacitors and resonators. *IEEE Trans.*, 1977, MTT-22(10), 857-64.
- Garg, R. & Long, S.A. Resonant frequency of electrically thick rectangular microstrip antenna. *Elect. lett.*, 1987, 23(21), 1149-159.
- Mishra, R.K. & Dash, S.K. Resonant frequency of cold plasma-embedded microstrip antenna. *Proc. APSYM-94, CUSAT*, Nov. 17-19, 1994, pp.176-79.
- Itoh, T. Spectral domain immittance approach for dispersion characteristics of generalised printed transmission line. *IEEE Trans.*, 1980, MTT-28, 733-36.

Contributors



Shri SK Dash obtained his MSc (Physics) in 1991 from Utkal University. At present, he is working in Department of Electronic Science, Berhampur University for his PhD. The areas of his research include patch antennas in free-space and plasma medium. He is a life member of ISTE.



Shri A Patnaik obtained his MSc (Electronic Science) in 1993 from Berhampur University. He has been working as Senior Research Fellow in the Department of Electronic Science, Berhampur University, for the Department of Energy (Govt. of India) sponsored project since 1995. The areas of his interest include patch antennas in free-space and plasma, application of ANN to microwaves, particularly to patch antennas and computer-aided design for patch antennas. He is a member of IEEE.



Shri GK Patra obtained his MSc (Electronic Science) from Berhampur University in 1994. He has been working as Senior Research Fellow at the Department of Electronic Science, Berhampur University for the Department of Energy (Govt. of India) sponsored project since 1995. The areas of his research include patch antennas in free-space and plasma, application of artificial neural networks to microwaves, particularly to patch antennas and computer-aided design for patch antennas.



Dr RK Mishra obtained his MSc (Physics) in 1987 from the Regional Engineering College, Rourkela and PhD in 1992 from UCE, Burla, both under Sambalpur University. He worked as Research Fellow in the Department of Electronics & Telecommunication Engineering, UCE, Burla, during 1987-1991. He has been working in the faculty of the Department of Electronic Science, Berhampur University, since 1991. At present, he is working on a major technology development project sponsored by the Department of Electronics, Government of India. He has published 25 research papers in national/international journals. His research area include microwaves, computer-aided design in microwaves, application of artificial neural networks in microwaves, active and passive patch antennas in free-space and plasma medium. He is a life member of ISTE and member of Institution of Electrical & Electronics Engineers.