

Hot Isostatic Pressing Technology for Defence and Space Applications

G. Appa Rao*, M. Sankaranarayana, and S. Balasubramaniam

Defence Metallurgical Research Laboratory, Hyderabad – 500 058, India

*E-mail: gouduapparao@rediffmail.com

ABSTRACT

Hot isostatic pressing (HIP) technology has been established for the development of AISI-304 stainless steel and nickel base superalloy Inconel 718 integral turbine rotors, for liquid propulsion engine of *Prithvi* missile, and cryoengine of geostationary satellite launch vehicle (GSLV), respectively. Before making the full size rotors, the structure – property relationships in hot isostatic pressed (HIPed) 304 stainless steel and superalloy 718 were established. The HIPed steel and superalloy have shown near 100 per cent theoretical density, homogeneous, and fine grained microstructure. Their mechanical properties were found to be in agreement with those specified for the integral turbine rotors and hence, development of full size near net shaped integral turbine rotors was undertaken. The HIPed steel rotors subjected to the static engine tests have shown a satisfactory performance, and therefore a large number of rotors could be produced to fulfill the requirement of target labs. The HIP technology for the integral turbine rotors was found to be cost effective (about 50 per cent) over the conventional fabrication method which involves forging, machining, and welding of blades to the disk. The processing, structure, and properties of the HIPed 304 stainless steel and superalloy 718 in relation to the performance of integral turbine rotors for missile and space vehicle applications are discussed in this paper.

Keywords: Austenitic stainless steel, Inconel 718, hot isostatic pressing, integral turbine rotors

1. INTRODUCTION

Hot isostatic pressing (HIP) is an innovative thermal treatment that subjects the materials to a combination of high pressure and high temperature¹. The process temperature is selected in such a way that during hot isostatic pressing the material yields or creeps in compression under the applied gas pressure. Inert gas like Argon is most commonly used as the pressure transmitting medium in HIP². Due to the combined action of both pressure and temperature, the porosity or internal voids present in the material are eliminated and near 100 per cent theoretical density is achieved in hot isostatic pressed (HIPed) materials. The component being HIPed retains its shape intact without the need for support tooling due to the isostatic nature of the pressure³. Figure 1 shows the typical configuration of a HIP unit available in the authors' laboratory.

Hot isostatic pressing has substantial potential for diffusion bonding of similar as well as dissimilar materials⁴. It is used to eliminate internal porosity in simple or complex shaped structural cast components made of a wide variety of materials including *Ni*- base superalloys, *Ti* and *Al* alloys as well as alloy steel etc. to improve the mechanical properties such as ductility and fatigue life¹. Not limited to metals, the HIP process is very versatile and used to densify ceramics, plastics, glasses, and many other materials. It may be noted that HIP is a best suited technique for consolidation of spherical shaped powders produced by inert gas atomisation (IGA) or plasma rotating electrode process (PREP) of highly alloyed materials into near net shaped components^{5,6}. In general the powder to be consolidated is taken in an evacuated sheet metal container of any desired shape and subjected to hot isostatic

pressing under the pressure of 100-200 MPa in the temperature range of 1000 °C - 1200 °C for about 3 h - 4 h of sustaining time. Depending on the material and the property requirement, the hot isostatic pressing variables are suitably selected. A typical HIP cycle for high temperature material like *Ni*-base superalloy is shown in Fig. 2. The rate of densification of powder mass during HIP is controlled by a number of processes such as particle rearrangement, plasticity power law creep,



Figure 1. Hot isostatic pressing facility at DMRL.

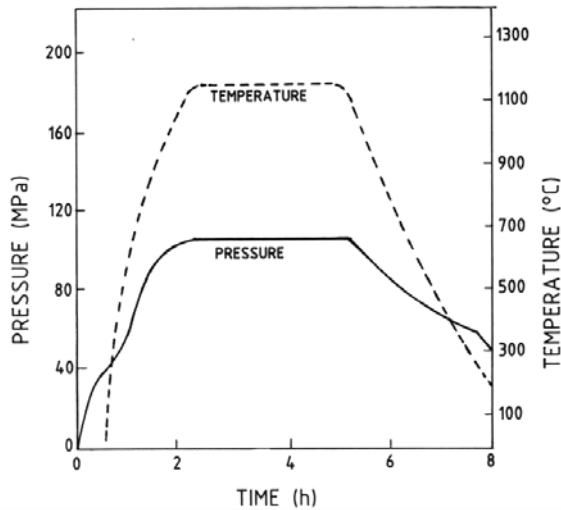

Figure 2. Pressure and temperature profiles of a typical HIP cycle for superalloy.

volume, and grain boundary diffusion acting simultaneously⁷. After HIP consolidation, the thin metal encapsulation can be easily removed by machining or chemical pickling. The HIPed component would thus need only a nominal material removal by machining to final dimensions depending on the accuracy and finish required. Sometimes, it is even possible to achieve a surface finish that would not need any subsequent machining. Main advantages of HIP technology include refined microstructure and isotropic mechanical properties, near net shape capability and high cost reduction potential. In view of these advantages, the HIP route has been adopted for the development of integral turbine rotors for missile and space vehicle applications. The details of the above component development work are presented in the following sections.

2. EXPERIMENTAL PROCEDURE

The prealloyed powders of AISI-304 stainless steel and superalloy Inconel 718 produced by inert gas atomisation (IGA) technique were used in the present work as this technique can yield the powder with a spherical shape which is an important requirement criterion for hot isostatic pressing of near net shaped components. The spherical shape combined with a wider particle size distribution of IGA powders exhibit a good packing density that aids in an effective filling of pre-shaped containers². This ultimately results in uniform shrinkage of capsules and thereby attainment of targeted dimensions with required level of accuracy/consistency in the HIPed products. The powders were chemically analysed for composition and also checked for their impurity levels particularly the oxygen content. Results of the chemical analysis on the as-received powders of AISI-304 stainless steel and superalloy IN 718 are presented in Tables 1 and 2, respectively. The morphology of the powder particles was examined in the scanning electron microscope (SEM). The physical properties such as median particle size, apparent density, tap density, and flow rate of powders required for present work were determined as per the ASTM standard methods and the data have been reported elsewhere^{8,9}. The powders were filled into stainless steel capsules of 10 mm internal diameter, 2 mm wall thickness and

200 mm length, out-gassed at room temperature, and also at elevated temperature of 800 °C for 8 h and then crimp sealed under a dynamic vacuum of 5×10^{-6} torr. The encapsulated powder was consolidated by hot isostatic pressing in an ASEA Quintus QIH-32 hot isostatic press at an optimised temperature in the range of 1100–1220 °C under the pressure of 100–130 MPa for an optimised sustaining time of 3 h. The density of the as-HIPed materials was measured by Archimedes principle. Optical microscopic examination was carried out on as-polished cross section of the HIPed compacts of steel and superalloy. Scanning electron microscopy (SEM) and electron probe micro analysis (EPMA) were carried out on the HIPed samples to study the various microstructural features. Transmission electron microscopy (TEM) was carried out on thin foils prepared from the selected samples to reveal the fine precipitates in the HIPed superalloy. The details of foil preparation and the TEM used in this study were reported elsewhere⁹. Tensile and stress rupture test specimens were prepared as per ASTM E 8 and E 139 standards, respectively¹⁰. Tensile tests were carried out on the as-HIPed and HIP+heat treated alloys using an Instron tensile testing machine at a constant cross-head speed of 1 mm/min, which results in an initial strain rate of $6.56 \times 10^{-4} \text{ s}^{-1}$ for the specimens with the gauge length of 25.4 mm used in the present study. Stress rupture tests were conducted at 650 °C under a stress level of 690 MPa for alloy 718 using Mayes creep testing machine, Model TC-20, having a lever ratio of 1:10. The SEM

Table 1. Chemical composition of AISI-304 stainless steel (wt. per cent)

Element	Gas atomised powder for (as received)	Specification wrought steel (IS: 6603) 1972
Cr	18.2	17-20
Ni	9.0	8-12
Mn	0.95	2.0 max
C	0.045	0.08 max.
Si	0.045	1.0 max
P	0.006	0.045 max
S	0.007	0.03 max
Fe	Balance	Balance
O	400 ppm	-

* Powder produced and supplied by M/s Osprey Metals Ltd, UK.

Table 2. Chemical composition of superalloy 718 (wt. per cent)

Element	Gas atomised specification powder sample *	AMS 5662J for wrought alloy
Cr	19.6	17 - 21
Fe	18.9	16 - 20
Nb	4.7	4.75 - 5.5
Mo	3.1	2.8 - 3.3
Al	0.5	0.2 - 0.8
Ti	0.8	0.65 - 1.15
C	0.03	0.08 max
O	275 ppm	-
Ni	Balance	Balance

* Powder produced and supplied by M/s Osprey Metals Ltd, UK.

fractography was performed on the tensile tested samples to investigate the fracture characteristics.

After realising the required metallurgical properties on test coupon level samples, processing of full size integral turbine rotors has been undertaken. One of the most important steps in the manufacture of near net shaped integral turbine rotors by HIP route is the production of ceramic cores of suitable shape by the injection moulding process and requisite encapsulation to contain the powder and cores. The shape of the ceramic core and the dimensions of the metal capsule have been worked out by taking into account the powder shrinkage characteristics after HIP consolidation. The ceramic core developed by the ceramics and composites group in DMRL and the sketch of a metal capsule assembly used in this study are shown in Figs 3 and 4, respectively.

As shown in Fig. 5 that the ceramic cores are assembled inside the slot provided in the grooved ring. The bottom lid along with the stainless steel tube at the centre is welded on to the ring. Atomised stainless steel powder with required physical properties is filled up to the maximum extent possible in the capsule containing the cores after which the top lid along with the stainless steel tube and evacuation tube welded on to the ring. The balance quantity of powder is filled up through the

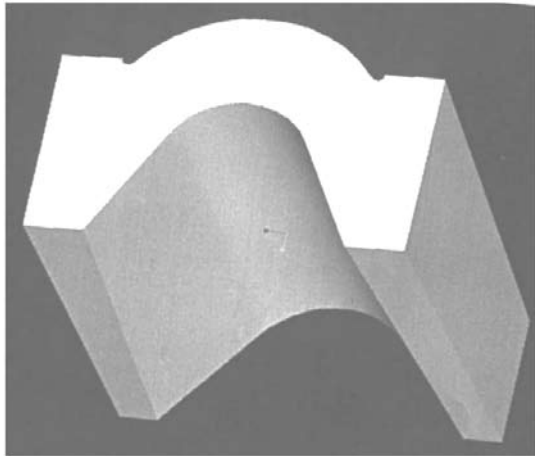

Figure 3. Ceramic core for stainless steel integral turbine rotor.

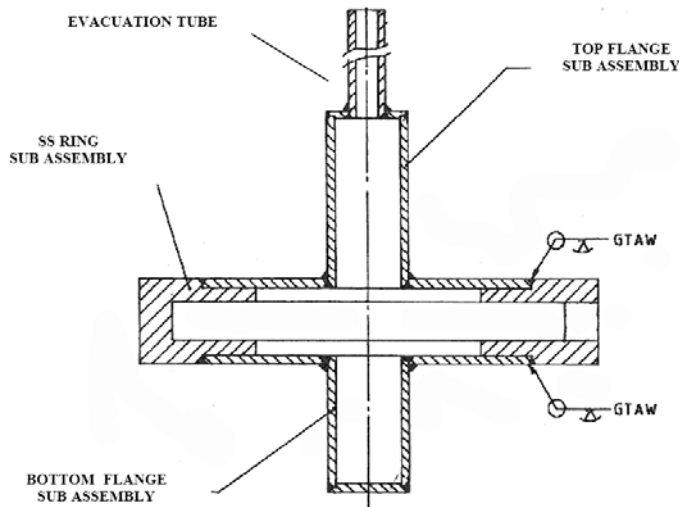

Figure 4. Schematic representation of a metal capsule assembly.

evacuation tube under vibratory conditions to ensure optimum packing of powder. The powder filled capsule is vacuum degassed as per the optimised schedule mentioned earlier and crimp sealed under dynamic vacuum conditions. The vacuum sealed capsules were subjected to hot isostatic pressing under optimised temperature, pressure and dwell time. The capsule of the rotor before hot isostatic pressing is shown in Fig. 6. The HIP consolidated rotor is machined on both sides to remove all the sheet metal encapsulation only to an extent when ceramic cores are exposed. The machined rotor is subjected to chemical pickling (leaching) in an autoclave containing 40 per cent of potassium hydroxide solution under 0.2-0.3 MPa pressure

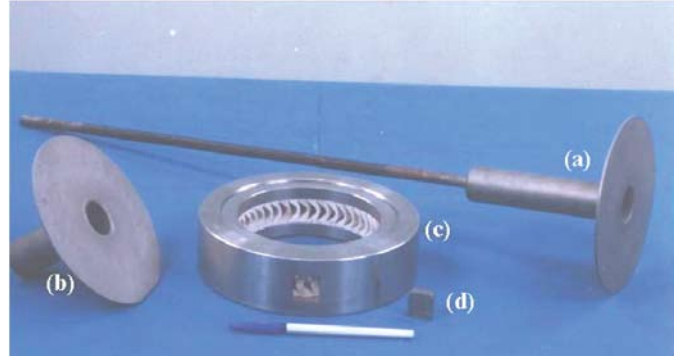

Figure 5. Capsule components: (a) top lid with evacuation tube, (b) bottom lid, (c) steel ring with ceramic cores assembled inside the slot, and (d) square plug.



Figure 6. Capsules of the rotor before hot isostatic pressing.

at a temperature of about 100 °C for 10-14 h to dissolve all the ceramic cores and finally the rotor is finish machined. Figure 7 shows finish machined HIPed stainless steel integral turbine rotor.

Metrological inspection of the machined rotor is carried out for the dimensional acceptability of the product. A few of the critical dimensions required to be checked are the outer diameter of rotor, disk diameter, blade width, blade radii, and blade angles. Nondestructive tests like X-ray radiography is also carried out on the rotor to ensure that the component is free from internal defects like porosity/ voids. Measurement of density, microstructural examination and mechanical property evaluation are carried out on the samples taken from the



Figure 7. Finish machined HIPed stainless steel integral turbine rotor.

extra portion cut from the shaft of the rotor to ensure that the component conforms to the requisite material property levels.

3. RESULTS AND DISCUSSION

Development of near net shaped integral turbine rotors from AISI-304 stainless steel and *Ni*-base superalloy 718 was the primary objective of this study. Before adopting the HIP route, various aspects of the conventional route for manufacture of rotors were examined and are described below.

3.1 Conventional Route for Manufacture of Integral Turbine Rotors

The stainless steel integral turbine rotor for Prithvi missile presented in Fig.7 consists of a disk of 126 mm diameter with 45 equispaced V-shaped axisymmetric blades with (22 mm long) radially emanating from its periphery and with a central shaft projecting on either side of it. The rotor after finish machining would weight 2.8 kg approx. with overall dimensions of 170 mm diameter, 155 mm length and 15 mm thickness at disk periphery. The conventional manufacturing process adopted for fabrication of this rotor is based on welding of machined blades on to a machined out disk shaft forging. The detailed steps in conventional fabrication include closed die forging of stainless steel block to a rough disk + shaft form, CNC milling of an extruded steel rod to get individual blade profile (over 900 machine man hours are estimated to be involved for machining all the 45 blades), machining of outer periphery of disk to house the machine blade in the fixture, TIG welding of blades route to the rim of disk and finish machining of welded area and machining of disc and shaft to the required dimensions.

A critical step in this type of manufacture is the welding of blade to the disc which should be of a very high quality to ensure reliability. Thus the welded joint is a potentially vulnerable aspect in the manufacture. Furthermore, 304 grade stainless steel can become susceptible to post weld degradation unless a very good care is exercised during welding and post weld treatments. Another main disadvantageous aspect of this route is very large amount of machining and involved specially for the blades and hence, a large production time for blade manufacture. Different work stations are involved to carry out fabrication of different portions of the component (closed die

forging, CNC machining, and welding, etc). Thus the overall production and delivery times for this component are for that matter any other similarly manufactured components tend to be long besides their considerable wastage of input material for machining. To overcome these limitations, HIP as an alternative route has been developed at DMRL for manufacture of integral turbine rotors.

3.2 HIP Technology for Manufacture of Integral Turbine Rotors

In HIP route, the entire component with integral blades can easily produced by suitably locating 45 numbers of appropriately shaped ceramic cores in all the blade to blade gaps prior to filling the powder in the metal capsules. It may be noted that the number of cores shall vary with respect to number of blades in the rotors. Powders are then filled into the stainless steel capsule, which subsequently subjected to degassing, hot isostatic pressing and machining operations to get the finished near-net shape rotor.

The HIP technology has obvious advantages over the non-integral welded approach of manufacturing. Since no welding is involved, the P/M version would be a component of much higher integrity. Further, near finish or almost finish blade profile can be easily achieved by this manufacturing route and also the number of process steps are drastically reduced. As a result, a highest cost reduction potential is realisable in the HIP route. Since, the rotor rotates around 25,000 rpm, stringent dimensional tolerances are required to be maintained on blade profiles to meet functional requirements of the rotor. The run outs of rotor should be minimum to keep the dynamic unbalance with acceptable limits of 5 g-mm. The dimension tolerances on HIPed rotor achieved were found to be within ± 0.30 mm on blade profile and the blade facial runouts were within 0.20 mm with which the rotor passes through dynamic balancing as well as the engine test. The technology established for stainless steel rotor was also adopted for the development of *Ni*-base superalloy integral turbine rotor for GSLV application. A typical HIPed superalloy 718 integral turbine rotor developed in DMRL for GSLV (ISRO) is shown in Fig. 8

As mentioned earlier that before going in for full size

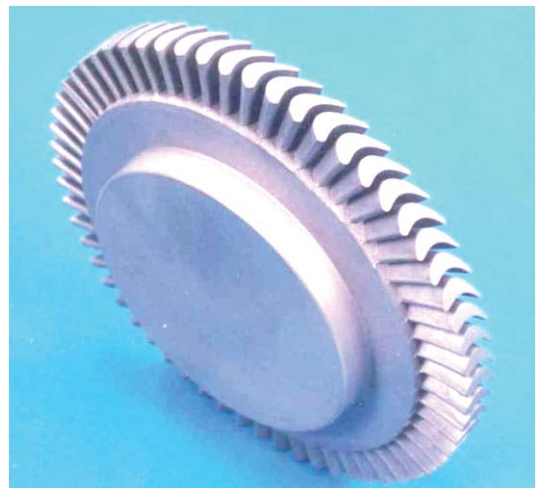

Figure 8. HIPed superalloy 718 integral turbine rotor.

components development, a detailed study was carried out on as-received powder, HIP processing, microstructure and mechanical properties of stainless steel and superalloy 718 and established the structure-property relationships in these materials. The study also included design and fabrication of HIP capsules for realising full size component with required dimensions and are discussed in the following sections.

3.3 Powder Characterisation and Hot Isostatic Pressing Parameters

The chemical composition of as-received stainless steel powder used in this study conforms to that of the austenitic stainless steel of AISI-304 grade Table 1. Apart from the desirable elements, the oxygen content of the powder was also determined. The oxygen level of powder is required to be as low as possible to avoid the formation of undesirable phases in HIPed material⁵. The particle morphology of the steel powder is near spherical and has satellite particles as can be seen in Fig. 9. The physical properties of the as-received powder such as median particle size, apparent density, tap density and flow rate, reported elsewhere⁸, are found to be suitable for hot isostatic pressing of integral turbine rotors¹¹. The chemical composition of alloy 718 powder conforms to the wrought IN 718 except that the oxygen content which is substantially high about 275 ppm. The physical properties of superalloys 718 were reported elsewhere have been found to be acceptable for hot isostatic pressing of near net shaped components⁹.

The hot isostatic pressing temperature, pressure and sustaining time intervals adopted in this study were in the range of 1100-1200 °C, 100-130 MPa and 3 h of sustaining time,

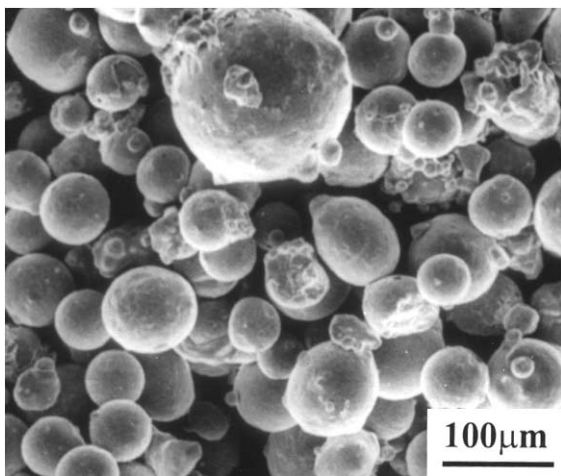

Figure 9. Particle morphology of inert gas atomised 304 stainless steel powder.

respectively. These conditions have conferred near theoretical density to stainless steel (8.0 g/cc) and superalloy 718 (8.2 g/cc).

3.4 Stainless Steel

Metallographic studies on the as-HIPed steel have confirmed that the steel is free from macro porosity which substantiates the measured density value of 8.0 g/cc. Due to considerable deformation of powder particles during hot isostatic pressing, the microstructure shows equiaxed grains with an average diameter of about 65 µm and the presence of annealing twins Fig.10. The microstructure further reveals that the HIPed steel is free from prior particle boundary (PPB) networks which are common and undesirable features in HIPed materials affect adversely the mechanical properties¹². The absence of PPBs is due to the fact that the steel does not have Al, Ti and Zr which show a greater affinity for oxygen that form stable oxides such as Al₂O₃, TiO₂ and ZrO₂ on the particle surface and prevent the metallurgical bonding between the particles during hot isostatic pressing.

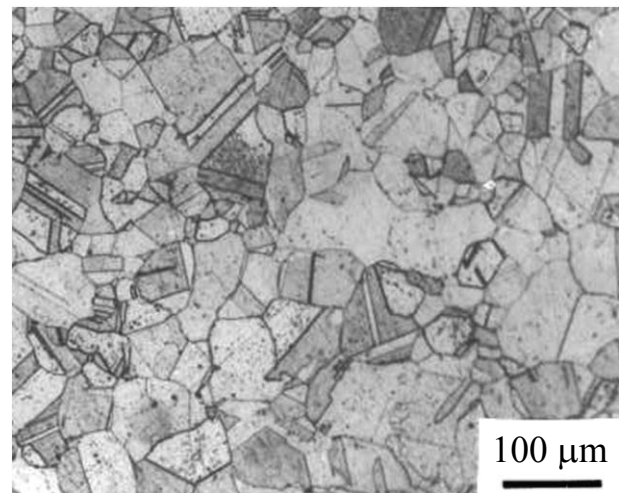

Figure 10. Microstructure of HIPed 304 stainless steel.

The room temperature tensile properties of HIPed steel together with the tensile data specified for conventionally processed wrought stainless steel are given in Table 3. It can be seen that the 0.2 per cent yield strength (YS), ultimate tensile strength (UTS), and the percentage elongation (EL), as well as the percentage reduction in area (RA) of the HIPed steel are much higher than those of the minimum specified values for the conventionally processed wrought steel. The superior strength and ductility of the steel can be attributed to its fine grain size and absence of significant inclusions and porosity. Impact strength and fracture toughness are the important material

Table 3. Room temperature tensile properties of HIPed stainless steel

Material processing details	0.2 per cent YS (MPa)	UTS (MPa)	EL (percentage)	RA (percentage)
As-HIPed	280	660	85	85
Specification for wrought alloy	200	490	40	40

YS: Yield strength, UTS: Ultimate tensile strength, EL: Elongation, RA: Reduction in area

properties for rotating applications. Results of the impact and plane strain fracture toughness tests carried out on the HIPed steel at ambient temperature were reported elsewhere showed that the HIPed steel has higher impact strength and fracture toughness K_{IC} when compared to the conventionally processed AISI-304 stainless steel^{8,13,14}. The deformation and fracture characteristics of the HIPed steel were studied¹⁵. The fracture surface of the HIPed steel tensile tested at room temperature presented in Fig. 11 reveals the presence of fine dimples. This indicates the nucleation of tiny voids and their coalescence leading to transgranular dimple rupture mode of failure which strongly supports high ductility of the HIPed steel. In view of its superior mechanical properties, the HIPed steel has been used for the development of near net shaped components for intended application¹⁶.

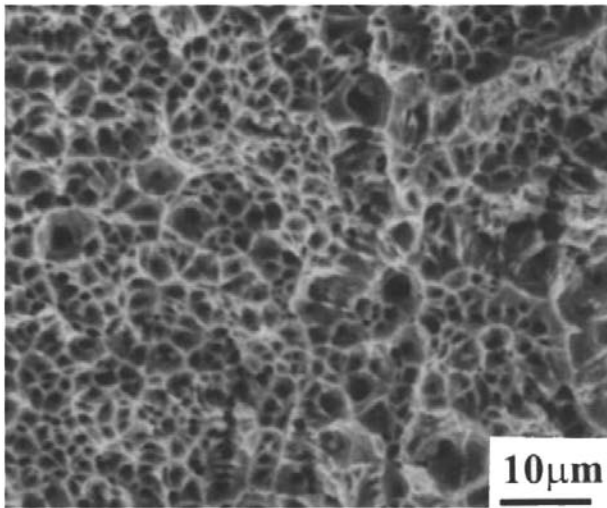

Figure 11. Fractograph of HIPed stainless steel tensile tested at room temperature.

3.5 Superalloy 718

The microstructure of the as-HIPed alloy 718 presented in Fig. 12 reveals equiaxed grains and annealing twins. The presence of most undesirable features such as prior particle boundary (PPBs) networks is seen in the micrograph. The PPB precipitates were found to be associated with Al_2O_3 and TiO_2

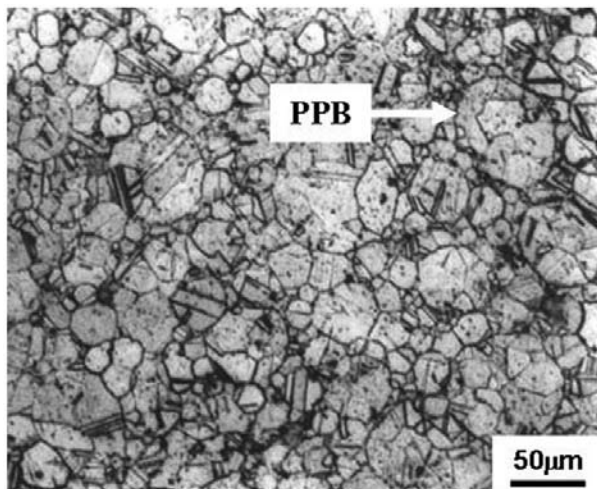

Figure 12. Microstructure of HIPed superalloy 718.

oxides and MC type carbides enriched with Nb and Ti ⁹. The grain size of the alloy in the as-HIPed condition was found to be about 25 μm . The TEM studies on as-HIPed alloy have revealed formation of fine scale strengthening precipitates such as γ'' and γ' in the matrix during slow cooling stage of hot isostatic pressing⁹.

To improve the strength, the HIPed alloy was given the standard heat treatment recommended for wrought alloy 718 as per AMS 5662J¹⁷. The microstructure of the HIP+ standard heat treated alloy shown in Fig. 13 reveals a high concentration of PPBs. The TEM micrograph of the heat treated alloy in Fig. 14 reveals extensive precipitation of strengthening precipitates during duplex heat treatment. As a result of this the tensile strength of the alloy were improved considerably, but the ductility and stress rupture properties were poor. The poor ductility and stress rupture properties have been attributed to the presence of prior particle boundary networks¹⁷. Substantial improvement in the high temperature ductility and stress rupture

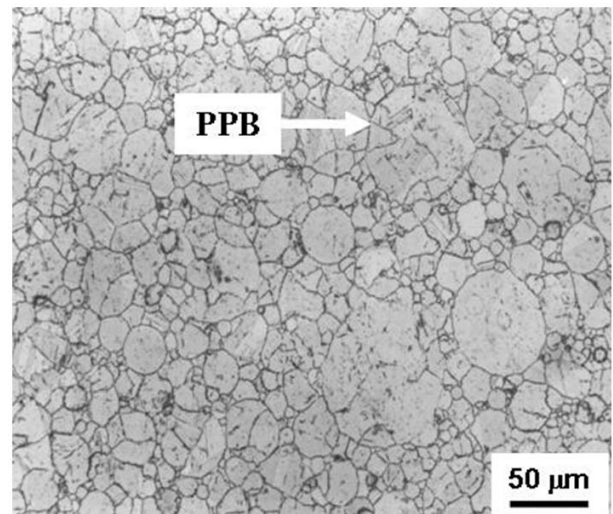

Figure 13. Microstructure of HIPed + heat treated superalloy 718.

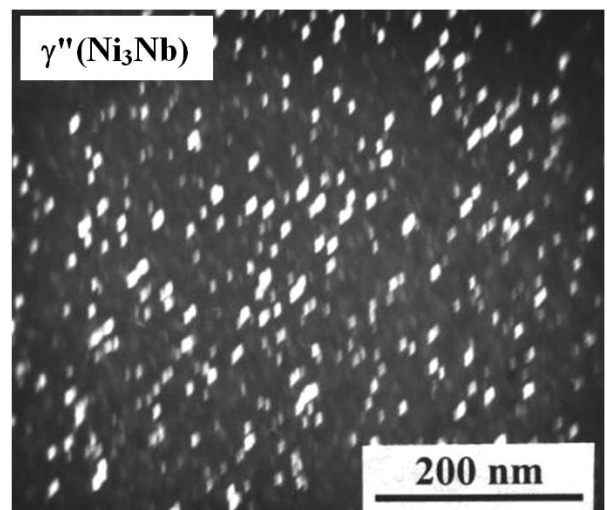

Figure 14. TEM micrograph of HIP + heat treated superalloy 718.

life could be achieved by thermomechanical treatment of HIPed material but the advantage of near-net shape of HIP technology was lost¹⁸. In view of this, a modified hot isostatic pressing and heat treatment schedules were adopted for alloy 718. The details of the modified processing were reported earlier¹⁹. The microstructure of the HIPed alloy processed under modified processing conditions presented in Fig. 15 reveals reduced PPB concentration. The modified processing conditions have resulted in improvement of ductility at room temperature and at 650 °C (Tables 4 and 5). The modified processing has also resulted in improvement of stress rupture properties (Table 6). In view of the application of the rotor in cryo engine which has a short span of life of the order of a few minutes the stress rupture life of 40 hours was considered to be adequate.

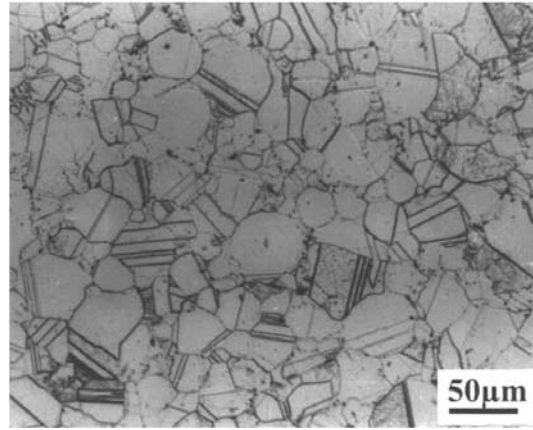

Figure 15. Microstructure of superalloy 718 processed under modified conditions.

Table 4. Tensile properties of superalloy 718 evaluated at room temperature

Material processing details	0.2 per cent YS (MPa)	UTS (MPa)	EL (percentage)	RA (percentage)
Processed under modified conditions	1220	1393	19.5	24.0
Wrought alloy as per AMS 5662 J	1030	1275	12.0	15.0

YS: Yield strength, UTS: Ultimate tensile strength, EL: Elongation, RA: Reduction in area

Table 5. Tensile properties of superalloy 718 evaluated at 650 °C

Material processing details	0.2 per cent YS (MPa)	UTS (MPa)	EL (percentage)	RA (percentage)
Processed under modified conditions	1041	1152	8.0	16.0
Wrought alloy as per AMS 5662 J	860	1000	12.0	15.0

YS: Yield strength, UTS: Ultimate tensile strength, EL: Elongation, RA: Reduction in area

Table 6. Stress rupture properties of superalloy 718

Material processing details	Test conditions	Rupture life (h)	EL (percentage)
Alloy processed under modified conditions	650 °C/690 MPa	40	4.0
Minimum specification values for wrought alloy as per AMS 5662 J	650 °C/690 MPa	23	4.0

4. CONCLUSIONS

- i. Hot isostatic pressing is a powerful and versatile technique for consolidation of spherical shaped powders into near net shaped components. This has been demonstrated by processing and development of integral turbine rotors from AISI-304 stainless steel and Ni-base superalloy Inconel 718 for defence and space applications.
- ii. The HIP processed integral turbine rotors exhibit homogeneous microstructure, consistent mechanical properties and acceptable dimensions that could meet the specification requirement.

- iii. The HIP technology for integral turbine rotors established in DMRL does not involve extensive machining and welding of blade profiles and there is a considerable saving in material as well as machining cost leading to overall cost reduction about 50 per cent over the conventional fabrication method.

ACKNOWLEDGEMENTS

The authors would like to thank Dr G. Malakondaiah, DS and Director, Defence Metallurgical Research Laboratory (DMRL); Prof D. Banerjee, DS and CCR&D; Dr N. Eswara

Prasad, Scientist G, and Dr M. Vijay Kumar, Scientist G and his team for their encouragement and immense support for this study. The co-operation extended by the members of PPG, MEG, CAD/CAM, MBG, Metallography, SEM and TEM groups in DMRL in the experimental work is gratefully acknowledged. Dr Amol A Gokhale, Outstanding Scientist and Associate Director, DMRL warrant special thanks for critical reviewing the manuscript.

REFERENCES

- Atkinson, H.V. & Rikinson, B.A. Hot Isostatic processing. Adam Hilger, Bristol, 1991.
- Isostatic Pressing Techniques, know-how Book 4:3, Vasteras, Sweden, ASEA Quintus, 1975.
- James, P.C. Isostatic pressing technology, Applied science publishers Ltd. London & NY, 1983, pp. 1-27.
- Appa Rao, G.; Sarma, K.S. & Kumar, M. Diffusion bonding of dissimilar P/M superalloys by hot isostatic pressing. Defence Metallurgical Research Laboratory, Hyderabad. Report No. DMRL TR 2000 265, Jan 2000.
- Price, P.E. & Kohler, S.P. hot isostatic pressing of metal powders, *In Metals Handbook*, 9th edn., Powder Metallurgy, Metals Park, Ohio, 1984, 7, 419-443.
- Goribov, G.S.; Zinoviev, V.A. & Buslavsky, I.S. Improvement in disk alloy quality due to application of powder metallurgy method and HIP. *In Advances in Powder Metallurgy and Particulate Materials*, Part-4, Metal powder industries federation, New Jersey, USA 1998.
- Lograsso, B.K. & Loggrasso, T.A. Densification during hot isostatic pressing. *In Proceedings of International Conference on HIP: Theory and Applications*, Gaithersburg, MD, USA, June 1989, pp. 115.
- Appa Rao, G. & Kumar, M. High performance stainless steel via powder metallurgy hot isostatic presses pressing. *Mater. Sci. Technol.*, 1997, 13, 1027-031.
- Appa Rao, G.; Prasad, K.S.; Kumar, M.; Srinivas, M. & Sarma, D.S. Characterization of hot isostatically pressed superally Inconel 718. *Mater. Sci. Technol.*, 2003, 19, 313-21
- Metals-Mechanical Testing: Elevated and Low-Temperature Tests: Metallography 1997 Annual book of ASTM Standards, Section 3, ASTM Committee on standards, 100 barr Harbor Drive, West Conshohocken, PA 19428, 1997, 03-01, 253-263
- Appa Rao, G. Influence of thermal and mechanical treatments on the structure and properties of HIPed superalloy 718. Banaras Hindu University, Varanasi, 2002. PhD Thesis.
- Podob, M.T. Effect of heat treatment and slight chemistry variation on the physical metallurgy of hot isostatically pressed low carbon astroloy powder. *In Modern developments in powder metallurgy*, edited by H.H. Hausner, & P.V. Taubenblat, Princeton, NJ, MPIF-APMI, 1977, 11, 25-44.
- Washko, S.D. & Aggen, G. Wrought stainless steels. *In Metals Handbook*, 10th edn., Properties and Selection: Iron, Steels and High-Performance Alloys, Metals Park, OHIO, 1990, 1, 854.
- Appa Rao, G.; Balasubramaniam, S. & Satyanarayana, D.V.V. Microstructure and mechanical behaviour of hot isostatically pressed materials for aerospace application. *Metals Materials Processes*, 2007, 19(1-4), 321-38.
- Appa Rao, G.; Satyanarayana, D.V.V.; Srinivas, M. & Sarma, D.S. Structure property correlations in hot isostatically pressed AISI-304 stainless steel. *Powder Metallurgy*, 2009, 52(3), 244-249.
- Balasubramaniam, S.; Sankaranarayana, M.; Appa Rao, G.; Chari, Y.N.; Sobhan Rao, G. & Dang, S.C. Quality assurance plan for integral turbine rotor manufactured by P/M (HIP) route. Defence Research and Development Laboratory, Hyderabad, DRDL Report No. 141-082-7006 November 1995.
- Appa Rao, G., Kumar, M.; Srinivas, M. & Sarma, D.S. Effect of standard heat treatment on the microstructure and mechanical properties of hot isostatically pressed superalloy Inconel 718. *Mater. Sci. Eng. A*, 2003, 355, 114-25.
- Appa Rao, G.; Srinivas, M. & Sarma, D.S. Effect of thermomechanical working on microstructure and mechanical properties of hot isostatically pressed superalloy Inconel 718. *Mater. Sci. Eng. A*, 2004, 383, 201-12.
- Appa Rao, G.; Srinivas, M. & Sarma, D.S. Influence of modified processing on structure and properties of hot isostatically pressed superalloy Inconel 718. *Mater. Sci. Eng. A*, 2006, 418, 282-291.

Contributor



Dr G. Appa Rao has obtained PhD (Metallurgical Engineering) from Banaras Hindu University, Varanasi in 2002. Presently working as a Scientist F and Head, Powder Processing Group, Defence Metallurgical Research Laboratory (DMRL), Hyderabad. He is actively involved in various R&D programmes towards development of HIPed hardware for defence, space, and nuclear applications. He has about 40 publications in national and international journals and conference proceedings. He is the life member of professional bodies such as Indian Institute of Metals, Powder Metallurgy Association of India, and Magnetic Society of India. His research areas include: Powder metallurgy and hot isostatic processing technology for high temperature materials.