

Parametric Study of Differential Absorption Lidar System for Monitoring Toxic Agents in the Atmosphere

S. Veerabuthiran and Jai Paul Dudeja

Laser Science and Technology Centre, Delhi-110 054

ABSTRACT

Differential absorption lidar (DIAL) techniques are advantageously used these days for detecting and monitoring traces of toxic agents located at several kilometers in the atmosphere. A theoretical study has been carried out to simulate the performance of a multiwavelength DIAL system. Clouds of hydrazine, unsymmetrical dimethylhydrazine (UDMH), and monomethylhydrazine (MMH), located at various ranges up to 5 km in the atmosphere, have been taken as examples of the toxic agents. It has been shown that a given lidar system cannot detect any of these agents with a specific cloud thickness if the concentration of that agent is below a certain value (N_{\min}). It has also been shown that if the concentration level of a given agent is above a certain value (N_{\max}) at a particular distance, this value cannot be quantified for a given lidar system although the identity as well as the location of that agent can still be determined. Further, for some typical parametric conditions, the required energy levels of the laser to detect specific concentrations of these agents at different distances have been computed. Power levels of the return signals and the SNR values from different ranges have also been calculated for each of these toxic agents for a given value of the laser transmitter energy.

Keywords: Differential absorption lidar, toxic agents, DIAL, remote detection, monitoring

1. INTRODUCTION

Remote detection of toxic agents in the atmosphere has attracted the interest of both military and civilian agencies. The differential absorption lidar (DIAL) is a powerful remote sensing technique for the rapid detection of a large number of such toxic agents present in the atmosphere due to industrial and vehicular exhausts, rocket propellants, chemical warfare, etc. In a DIAL system, the concentration of the agent is determined from the ratio of strengths of return signals at two closeby wavelengths, known as online and offline wavelengths, such that the agent has strong absorption at the former wavelength and relatively weak absorption at the latter wavelength.

Many of these agents have distinct absorption bands in the 9-11 μm region, and there is relatively less atmospheric attenuation in this spectral region. Tunable TEA CO_2 lasers have commonly been used¹ for the detection of these toxic agents. Some of the remaining agents can be detected using tunable sources in the 2-5 μm region²⁻⁴.

A theoretical study has been carried out to determine the required parameters of a multiwavelength DIAL system for the detection of a cloud of specific thickness each of hydrazine, unsymmetrical dimethylhydrazine (UDMH), and monomethylhydrazine (MMH) located one at a time, at various distances up to 5 km in the atmosphere. These compounds

are used as rocket fuels and are highly toxic. Exposures to hydrazine, for example, may cause toxic damage to the liver (fatty liver) and kidney (interstitial nephritis) as well as anemia⁵. The possibility of accidental release of these toxic compounds into the atmosphere makes it important to sensitively monitor their presence and measure their concentration in the atmosphere. Here, it has been shown that a given lidar system cannot detect any of these agents with a specific cloud thickness if the concentration of that agent is below a certain value (N_{\min}). It has also been shown that if the concentration level of a given agent is above a certain value (N_{\max}) at a particular distance, this value cannot be quantified for a given lidar system although the identity as well as the location of that agent can still be determined. Further, for some typical parametric conditions, the required energy levels of the laser to detect specific concentrations of these agents at different distances have been computed. Power levels of the return signals and the SNR values from different

ranges have also been calculated for each of these toxic agents for a given value of the laser transmitter energy.

2. SYSTEM OVERVIEW

Figure 1 shows a schematic diagram of the proposed DIAL system⁶. The lidar system has a transmitter, receiver, microcontroller, data acquisition and data processing units. A 50 cm dia Cassegrain telescope is used to collect the backscattered signal. The transmitting and receiving telescopes, which are coaxially aligned, are mounted on Gimbals. Receiving telescope is connected to the detector box that contains spectral filters and detectors. There are two detectors, one each for the detection of signals at 2-5 μm and 9-11 μm regions. A bandpass filter permits the lidar signals to reach the respective detectors while blocking any stray light outside the wavelength range of interest. The detected signals are passed through A/D converters and data processors,

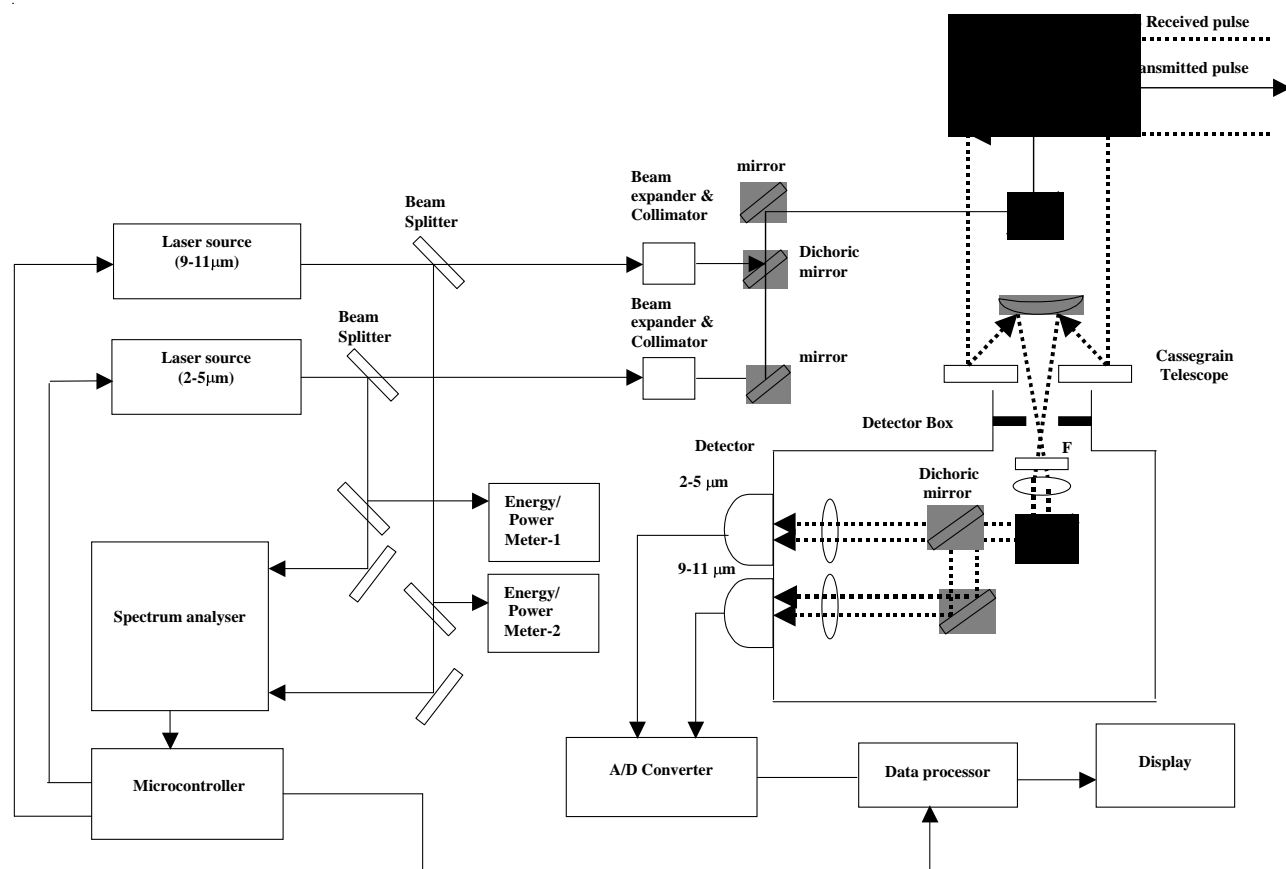

Figure 1. Schematic diagram of multiwavelength differential absorption lidar system.

etc. The data processor consists of a 6 MHz digitiser and a computer for data storage. Table 1 describes the details of the system parameters used.

Table 1. DIAL system parameters used

Parameter	Specifications
Transmitted energy at online and offline (E_t)	200 mJ
Pulse width (τ)	100 ns
Pulse repetition frequency (n)	100 Hz
Dia of telescope mirror (D)	50 cm
Detectivity of the detector (D^*)	$3 \times 10^9 (m\sqrt{\text{Hz}}/W)$
NEP	$1.45 \times 10^{-9} W$
Dia of the detector (d)	2 mm
Electrical bandwidth of detector (B)	100 MHz

3. SYSTEM ANALYSIS

3.1 Lidar Equation

If a laser pulse of duration τ , wavelength λ , and peak power P_t is transmitted at time t_o along an atmospheric path, the received power P at time t from a distance R [$R=c(t-t_o)/2$] in the single scattering hypothesis is given by the following expression²:

$$P(\lambda, R) = P_t \left(\frac{c\tau}{2} \right) \beta(\lambda, R) \xi(\lambda) \xi(R) \frac{A}{R^2} \cdot \exp \left[-2 \int_0^R \alpha dR \right] \cdot \exp \left[-2 \int_{R_1}^{R_2} \sigma N dR \right] \quad (1)$$

where c is the velocity of the light, $\beta(\lambda, R)$ is the volume backscattering coefficient of the atmosphere, $\xi(\lambda)$ is the receiver's spectral transmission factor which includes the influence of any other elements such as monochromator, $\xi(R)$ is the probability of return pulse reaching the detector from a distance R , A is the effective receiver area, α is the extinction/attenuation coefficient of the atmosphere due to scattering from aerosols and absorption by molecules other than the toxic agent, and σN is the contribution from the absorbing toxic agent (σ is the absorption cross-section and N is the number density of that agent), and it is assumed that the concentration of

the toxic agent cloud is located between R_1 and R_2 ($R_2 - R_1 = \Delta R$) within the range R .

The extinction coefficient (α) is primarily due to Mie scattering in the wavelengths of our interest in IR region. It depends on the aerosol size, distribution, shape, concentration, and also the atmospheric conditions. For calculations, the following empirical relation between α and the visual range⁷ has been used:

$$\alpha = \frac{3.91}{V} \left(\frac{0.55}{\lambda} \right)^{0.585V^{1/3}} \text{ km}^{-1} \quad (2)$$

where V is the visual range in km and λ is in micron. The backscattering coefficient $\beta(\lambda, R)$ is computed from its relation with α , which is given by⁸

$$\alpha = K\beta \quad (3)$$

The value of K depends upon the wavelength of the transmitted beam as well the composition, size, and shape of the aerosols and the atmospheric condition. In the wavelength ranges of interest in the present paper and in the typical local atmospheric conditions comprising dust, haze or light, smoke, K has a value⁸ of approximately 100. For calculations here, $K=100$ is taken.

3.2 Equations for Return Signals and Concentration of the Agent Cloud

Let two wavelengths be considered for the molecules of the toxic agent of interest: one corresponding to the peak of the absorption line λ , termed as online wavelength and the other corresponding to a minimum of absorption λ' , termed as offline wavelength. By rewriting Eqn (1) for these two wavelengths, one obtains the following equations for return signals (powers) from the distances R_1 and R_2 at λ and λ' :

Return power (P_1) at λ from R_1 :

$$P_1(\lambda, R_1) = P_t \left(\frac{c\tau}{2} \right) \beta_1(\lambda, R_1) \xi(\lambda) \xi(R_1) \frac{A}{R_1^2} \cdot \exp \left[-2 \int_0^{R_1} \alpha dR \right] \quad (4)$$

Return power (P_2) at λ from R_2 :

$$P_2(\lambda, R_2) = P_t \left(\frac{c\tau}{2} \right) \beta_2(\lambda, R_2) \xi(\lambda) \xi(R_2) \frac{A}{R_2^2} \cdot \exp \left[-2 \int_0^{R_2} \alpha dR \right] \cdot \exp \left[-2 \int_{R_1}^{R_2} \sigma N_a dR \right] \quad (5)$$

Return power (P'_1) at λ' from R_1 :

$$P'_1(\lambda', R_1) = P'_t \left(\frac{c\tau}{2} \right) \beta'_1(\lambda', R_1) \xi'(\lambda') \xi(R_1) \frac{A}{R_1^2} \cdot \exp \left[-2 \int_0^{R_1} \alpha' dR \right] \quad (6)$$

Return power (P'_2) at λ' from R_2 :

$$P'_2(\lambda', R_2) = P'_t \left(\frac{c\tau}{2} \right) \beta'_2(\lambda', R_2) \xi'(\lambda') \xi(R_2) \frac{A}{R_2^2} \cdot \exp \left[-2 \int_0^{R_2} \alpha' dR \right] \cdot \exp \left[-2 \int_{R_1}^{R_2} \sigma' N_a dR \right] \quad (7)$$

Here P_t and P'_t are the laser transmitted powers at λ and λ' , respectively; and N_a is the concentration of the agent (number of molecules/m³) averaged over the range cell ($R_2 - R_1 = \Delta R$). For convenience, $P_t = P'_t$ has been assumed (corresponding to $E_t = 200$ mJ) although one can take these values differently and perform the computations.

Further, it has been assumed that λ and λ' are so close to each other that these satisfy the following criterion:

$$|\lambda' - \lambda| \leq \frac{|\beta' - \beta|}{\beta k} \lambda \quad (8)$$

Here, for Mie scattering in the atmosphere, in the IR region of our interest, the value of k varies⁹ between 1.2 and 2.5. (Note that k has a maximum value equal to 4, which is in the case of Rayleigh

scattering). In addition to this condition, if measurements at λ and λ' are made near-simultaneously⁶, one can assume that $\alpha \cong \alpha'$. Taking this approximation and after simplifying Eqns (4)-(7), one gets the following range-resolved expression for the concentration N_a of the specific agent of cloud thickness, ΔR :

$$N_a = \frac{1}{2(\Delta\sigma)(\Delta R)} \left\{ \ln \left(\frac{P_1}{P'_1} \right) + \ln \left(\frac{P_2}{P'_2} \right) + \ln \left(\frac{\beta'_1 \beta_2}{\beta_1 \beta'_2} \right) \right\} \quad (9)$$

3.3 Equations for Signal-to-noise Ratio and Transmitted Energy

The noise contributions arise from the combined effects of detector dark noise and the received background radiation. In the mid-IR range (range of our interest), both the solar and terrestrial thermal radiation contributions are very small, and hence, can be neglected. While the dark noise is negligible for good detectors in the visible and near-IR, the detectors in the mid-IR have fairly large dark noise¹⁰. Since the origin of this dark noise is thermal in nature, cooling the detector to liquid N_2 temperature (77 K) reduces the dark noise contributions significantly. It should be noted¹¹ that whereas the detector noise in the case of heterodyne (coherent) lidar with sufficient local oscillator power is shot-noise limited (noise value $\cong 10^{-12}$ W), for direct (non-coherent) lidar system with weak return signals, it is dark-current limited in the mid-IR spectral region. Note that the SNR is now range-dependent and, for the case of thermal-background limited case, the SNR of solid-state detector is given by¹⁰

$$\text{SNR} = \sqrt{n} \frac{P}{\text{NEP}} \quad (10)$$

where P is the received power, NEP is the noise equivalent power of the detector and n is the number of received pulses. In the dark-current limited case, NEP of the detector is given by

$$\text{NEP} = \frac{\sqrt{A_d B}}{D^*} \quad (11)$$

where D^* is the detectivity, A_d is the area of the detector, and B is the detection bandwidth. From

Eqns (1), (10), and (11), one can rewrite the SNR equation (for $n=1$) as

$$\text{SNR} = \frac{D^* E_t \xi(\lambda) \xi(R) \beta A c}{2R_2^2 \sqrt{A_d B}} \exp\left[-2 \int_0^{R_2} \alpha dR\right] \exp\left[-2 \int_{R_1}^{R_2} \sigma N dR\right] \quad (12)$$

where E_t is the transmitted energy per pulse. By rearranging Eqn (12), the required energy to be transmitted in the atmosphere for single pulse can be computed for given SNR values, which is given by

$$E_t = \frac{2R_2^2 \sqrt{A_d B} (\text{SNR})}{D^* c \xi(\lambda) \xi(R) \beta A} \exp\left[+2 \int_0^{R_2} \alpha dR\right] \exp\left[+2 \int_{R_1}^{R_2} \sigma N dR\right] \quad (13)$$

3.4 Absorption Cross-sections and other Parameters used in Computations

Using above equations, one can now proceed to compute values of various parameters of the proposed multiwavelength DIAL system for the detection of toxic agents. Three representative cases of toxic agents (hydrazine, UDMH and MMH) have been considered for this purpose. The details of these agents, their absorption cross-sections at on-and off-wavelengths are listed¹² in Table 2. These wavelengths have been chosen to ensure that there are minimal interference effects from other normally occurring agents near these wavelengths. Among the potential interfering species, ethylene

and ammonia are of particular importance at these wavelengths. If one refers the table in Menyuk's¹² work, the units of absorption coefficients are given in $\text{cm}^{-1} \text{atm}^{-1}$. Now, referring to Collis¹³, this is actually equal to $N_0 (\text{cm}^{-3} \text{atm}^{-1}) \times \sigma (\text{cm}^2)$, where N_0 is the air molecule density per atmosphere. To get the values of σ (in cm^2), one has to simply divide the absorption coefficients, listed in Menyuk's¹² work, by $N_0 (=2.69 \times 10^{19} \text{ cm}^{-3} \text{atm}^{-1})$. For example, from the value of absorption coefficient $4.77 \text{ cm}^{-1} \text{atm}^{-1}$ (for hydrazine at $\lambda=10.611 \mu\text{m}$), one gets $\sigma = 1.77 \times 10^{-19} \text{ cm}^2 = 1.77 \times 10^{-23} \text{ m}^2$. Accordingly, the values of σ for the three hydrazine-compounds are listed in Table 2, and are used in the calculations.

For simulation, a 200 m thick layer ($=\Delta R$) of toxic agent cloud has been considered, although the software program is general in nature and can cater to different values equally well. Aerosol concentration in the atmosphere is taken to be uniform. For the sake of simplicity, the effect of wind velocity on the concentration levels and the dispersion of toxic-agent cloud have not been considered. Although important, but the authors propose to incorporate this aspect in their subsequent work. Further, they have taken the values for $\xi(\lambda) = 0.8 = \xi(R)$ in their calculations.

5. COMPUTATION OF SYSTEM PARAMETERS

5.1 Minimum Detectable Concentration (N_{\min})

If the online and offline wavelengths are so close to each other that the atmosphere behaves identically for both the lines, one can assume the reasonable approximations, viz., $P_1 \cong P'_1$, $\beta_1 \cong \beta'_1$, and $\beta_2 \cong \beta'_2$ in Eqn (9). One then gets

Table 2. Absorption cross-sections of hydrazine rocket fuels

Species	Online wavelength λ (μm)	Absorption cross-section, σ at λ (m^2)	Offline wavelength λ' (μm)	Absorption cross-section, σ' at λ' (m^2)	$\Delta\sigma = \sigma - \sigma'$ (m^2)
Hydrazine	10.611 P(22)	1.77×10^{-23}	10.675 P(28)	0.77×10^{-23}	1.00×10^{-23}
Unsymmetrical Dimethylhydrazine (UDMH)	10.696 P(30)	0.83×10^{-23}	10.318 R(10)	0.07×10^{-23}	0.76×10^{-23}
Monomethylhydrazine (MMH)	10.182 R(30)	0.63×10^{-23}	9.282 R(18)	0.12×10^{-23}	0.51×10^{-23}

$$N_a \cong \frac{1}{2(\Delta\sigma)(\Delta R)} \ln\left(\frac{P'_2}{P_2}\right) \quad (14)$$

For the return signals P_2 and P'_2 to be distinguishable from each other, it is essential that these satisfy the following criterion for the given detector:

$$\Delta P = P'_2 - P_2 \geq NEP \quad (15)$$

From Eqn (9), for $n=1$, one gets

$$NEP = \frac{P_2}{SNR} \quad (16)$$

From Eqns (14) - (16), one gets

$$N_a \geq \frac{1}{2(\Delta\sigma)(\Delta R)} \ln\left(1 + \frac{1}{SNR}\right) \quad (17)$$

From this, one gets an expression for the minimum detectable concentration (N_{min}) as

$$N_{min} = \frac{1}{2(\Delta\sigma)(\Delta R)} \ln\left(1 + \frac{1}{SNR}\right) \quad (18)$$

For performance evaluation of the proposed lidar system, one shall take $SNR = 10$ for distinguishably measurable return signals. So, after substituting this value of SNR as well as $\Delta R = 200$ m in Eqn (18), one gets

$$N_{min} = \frac{2.383 \times 10^{-4}}{(\Delta\sigma)} \quad (19)$$

Applying Eqn (19) and the data in Table 2, one gets 0.886 ppm, 1.166 ppm and 1.737 ppm as the values of N_{min} for hydrazine, UDMH, and MMH, respectively. It may be noted here that this value of $N_{min} = 0.886$ ppm for hydrazine, for example, is less than its threshold limit value⁵ of 1 ppm. Here ppm is the concentration of the given toxic gas. As is well known that, at STP, 2.69×10^{19} molecules would occupy 1 cm^3 of volume (= one millionth of 1 m^3). Therefore, 1ppm concentration of any toxic gas means that 2.69×10^{19} molecules

$$\left(= \frac{6.02 \times 10^{23} (= Avogadro's.Number)}{22.4 \times 10 \text{ cm}^3} \right)$$

would occupy 1 cm^3 of volume (= one millionth of 1 m^3). Therefore, 1 ppm concentration of any toxic gas means that 2.69×10^{19} molecules (or atoms) of that agent are dispersed within 1 m^3 of the atmosphere.

As can be seen that out of these values of N_{min} , the same for MMH is the highest. In order that our proposed lidar system should be able to detect all the three agents, one has to choose a value of N for doing the performance evaluation of the system. So, a value of $N = 2$ ppm has been selected and the requisite parameters of the system have been computed so that these agents are detectable up to 5 km in the atmosphere.

5.2 Maximum Detectable Concentration (N_{max})

To calculate the value of N_{max} , it is seen from Eqns (4)-(7) that out of all the return signals, P_2 has got the lowest value under the given conditions. This is obvious due to the strong absorption of radiation at the online wavelength and consequent attenuation of the beam strength in the agent cloud. So, the attention was turned on P_2 and Eqn (5) to rearrange get an expression for the concentration (N_a) of the agent cloud as

$$N_a = \frac{1}{2\sigma(\Delta R)} \ln\left(\frac{E_t c A \beta_2(\lambda, R_2) \xi(\lambda) \xi(R_2)}{2P_2 R_2^2}\right) - \frac{\alpha R_2}{\sigma(\Delta R)} \quad (20)$$

Using Eqn (9) and considering $SNR=10$ as the minimum acceptable value, one gets from Eqn (20), an expression for the maximum detectable concentration (N_{max}) as

$$N_{max} = \frac{1}{2\sigma(\Delta R)} \ln\left(\frac{E_t c A \beta_2(\lambda, R_2) \xi(\lambda) \xi(R_2)}{20(NEP)R_2^2}\right) - \frac{\alpha R_2}{\sigma(\Delta R)} \quad (21)$$

The return signal for a concentration greater than N_{\max} of the agent cloud will be too low to be measurable. Therefore, a concentration above this value cannot be measured by the given lidar system in the given conditions. Although the identity of the agent can still be known (by observing the online wavelength at which the return signal suddenly dropped to immeasurable levels). Further, the location of the agent can also be accurately known (by measuring the time lapsed between the transmitted and the return pulses). By substituting the values from Tables 1 and 2, one gets the 5.43 ppm, 11.52 ppm, and 15.60 ppm as the maximum detectable concentrations of hydrazine, UDMH, and MMH, respectively.

Thus one can see that a given lidar system can detect concentration levels of a specific agent, which satisfy the criterion: $N_{\min} \leq N_{\text{detectable}} \leq N_{\max}$.

5.3 Required Transmitted Energy per Pulse of Laser

Using Eqn (13) and the parameters listed in Tables 1 and 2, one can compute the required transmitted energy per pulse ($= E_t$) of the laser to detect a toxic agent concentration of 2 ppm (which is equivalent to $2 \times 2.69 \times 10^{19}$ molecules of the agent per m^3) for different values of R_2 . The value of SNR has been taken to be equal to 10 and $\Delta R = 200$ m. For simplicity, the effect of wind velocity is not considered in this paper. The results are shown in Figs 2(a), 3(a), and 4(a) for the toxic agents hydrazine, UDMH, and MMH, respectively. For example, one can see that with $\Delta R=200$ m, at $R_2 = 5$ km, the values of required E_t at online wavelengths are equal to 84.19 mJ, 70.98 mJ, and 69.77 mJ to detect 2 ppm each of hydrazine, UDMH, and MMH, respectively. Thus one can conclude that if one has a pulsed laser with $E_t = 200$ mJ (the value in the proposed system) at each of these wavelengths, it can easily detect 2 ppm concentration of these agents located up to 5 km.

5.4 Power of Return Signals

Now the power levels of the return signals are computed at the online wavelengths from different ranges for hydrazine compounds by using Eqn (5). The results are shown in Figs 2(b), 3(b), and 4(b)

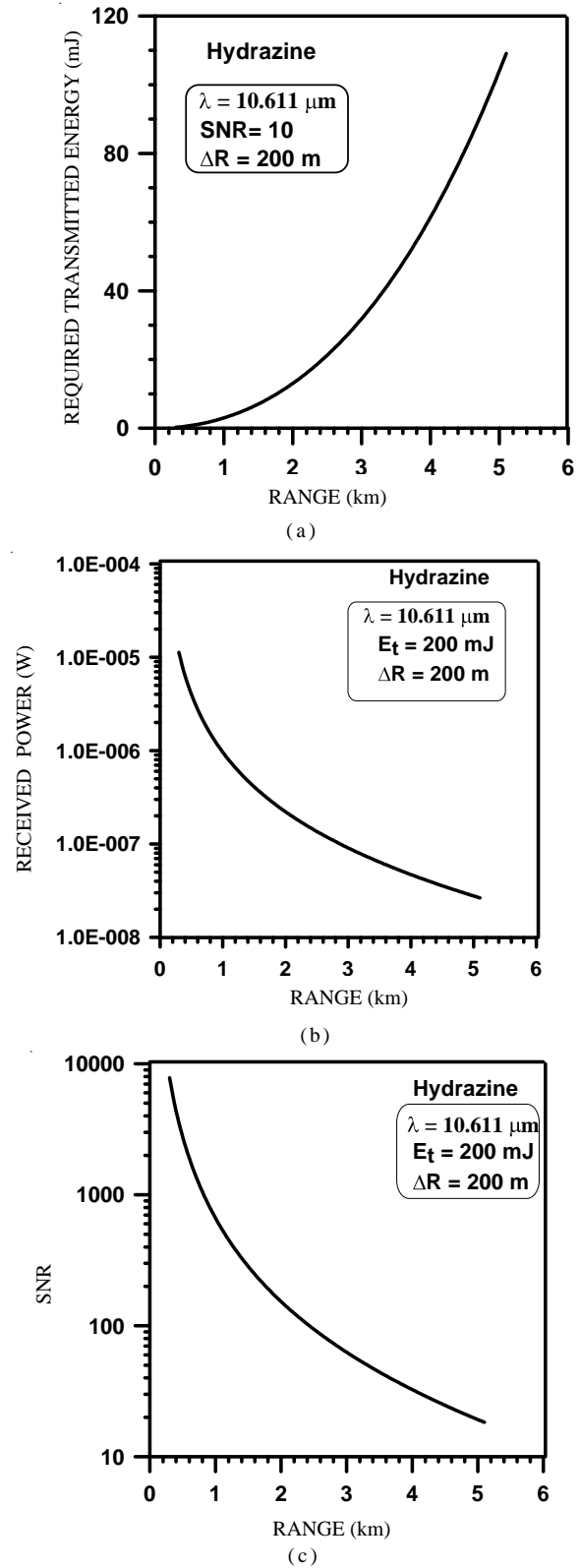

Figure 2. Toxic agent hydrazine: (a) required energy per pulse of laser transmitter for different ranges, (b) received power for different ranges, and (c) SNR at different locations of the agent.

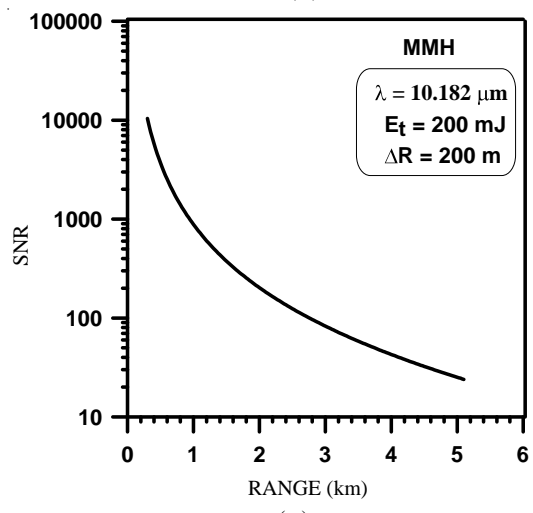
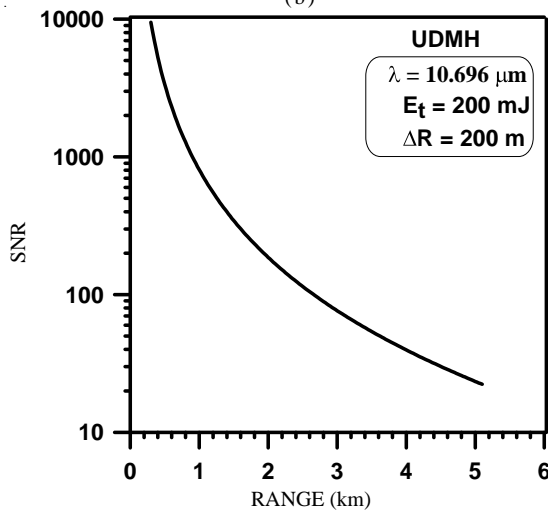
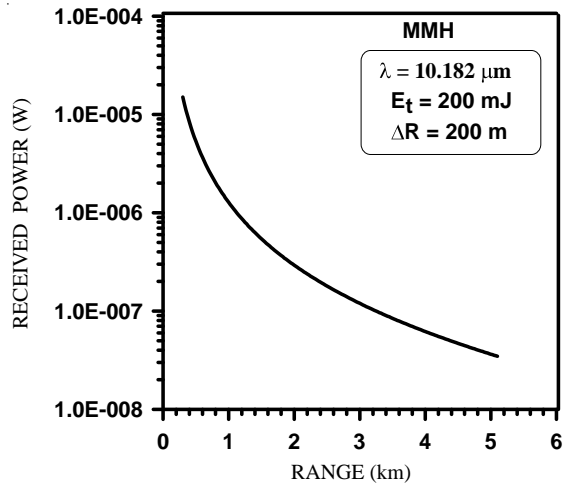
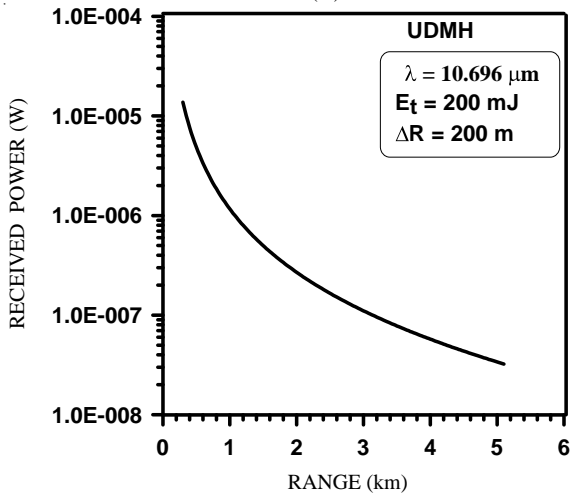
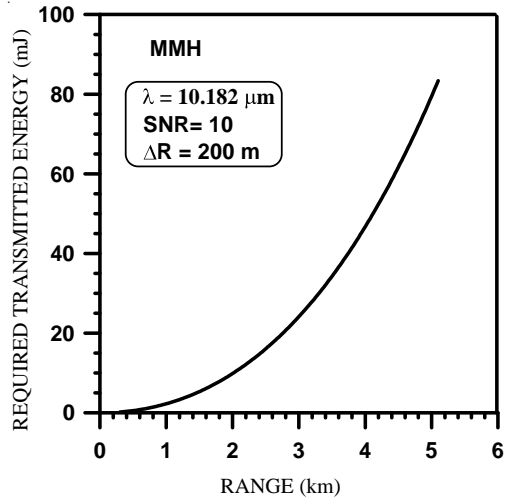
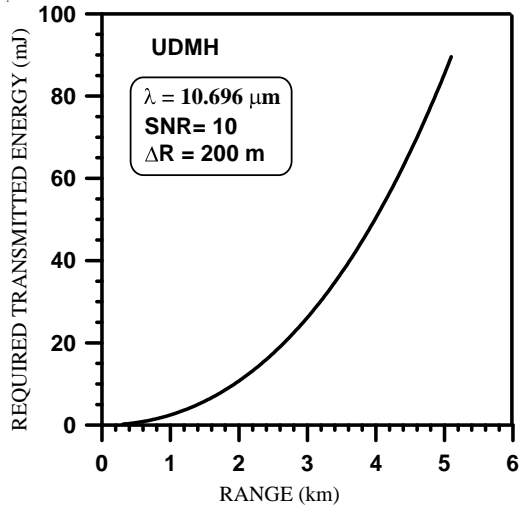

Figure 3. Toxic agent UDMH: (a) required energy per pulse of laser transmitter for different ranges, (b) received power for different ranges, and (c) SNR at different locations of the agent.

Figure 4. Toxic agent MMH: (a) required energy per pulse of laser transmitter for different ranges, (b) received power for different ranges, and (c) SNR at different locations of the agent.

for the toxic agents hydrazine, UDMH, and MMH, respectively. For example, one can see that with $\Delta R = 200$ m, at $R_2 = 5$ km, the values of required P_2 at online wavelengths are equal to 34.4 nW, 40.8 nW, and 41.5 nW to detect 2 ppm each of hydrazine, UDMH, and MMH, respectively.

5.5 Signal-to-noise Ratio of Return Signals

Finally, the SNR values of the return signals are computed by using Eqn (12). Any discernible detection requires the lidar signal to exceed the NEP by an adequate margin. The results shown in Figs 2(c), 3(c), and 4(c) illustrate that the return signals are well above the noise floor. The SNR values corresponding to km are 23.76, 28.18 and 28.67 for hydrazine, UDMH, and MMH, respectively.

6. CONCLUSION

In this study, it is observed that the given lidar system, with the specified parameters, cannot detect a concentration of the agent below a certain value, N_{\min} . It has also been shown that if the concentration level of a given agent is above a certain value, N_{\max} , this value cannot be detected for a given lidar system although the identity as well as the location of that agent can still be determined. Thus, one can see that a given lidar system can detect concentration levels of a specific agent, which satisfy the criterion: $N_{\min} \leq N_{\text{detectable}} \leq N_{\max}$. One can then compute the required energy levels of laser, the received power levels, and their SNR values to detect a given layer of thickness of hydrazine, UDMH, MMH at various ranges up to 5 km in the atmosphere. It is shown that a 200 mJ energy of CO_2 DIAL lidar system, operating in 9-11 μm spectral region, is more than sufficient to detect 2 ppm concentration and 200 m thickness of each of these toxic agents located anywhere in the ambient atmosphere up to 5 km. The received backscattered signals are well above the noise floor of the detector system.

ACKNOWLEDGEMENTS

The authors express their gratitude to Dr Anil Kumar, Director, LASTEC, Delhi, for his constant encouragement and support.

REFERENCES

1. D'Amico, F.M.; Vanderbeck, R.G. & Warren, R.G. Range resolved frequency agile CO_2 lidar measurements of smokestack vapour effluents. *Proceedings SPIE*, 1999, **3855**, 128-33.
2. Degtiarev, E.V.; Geiger, A.R. & Richmond, R.D. Compact dual wavelength 3.30-3.47 μm DIAL lidar. *Proceedings SPIE*, 2000, **4036**, 229-35.
3. Prasad, C.R.; Kabro, P. & Mathur, S. Tunable IR differential absorption lidar for remote sensing of chemicals. *Proceedings SPIE*, 1999, **3757**, 87-95.
4. Baumgartner, R.A. & Byer, R.L. Remote SO_2 measurements at 4 μm with a continuously tunable source. *Optical Letters*, 1978, **2**, 163-65.
5. Hurst, Gerald L. glhurast@onr.com <http://64.233.167.104/search?q=cache:CrAqQb7OX7EZ:yarchive.net/explosives/hydrazine>. [Accessed on 2 September 1995].
6. Dudeja, J.P. Design and development of lidar system for the detection of chemical and biological agents. Laser Science and Technology Centre (LASTEC), Delhi, 2003. Technical Appreciation Report.
7. Kildal, H. Comparison of laser methods for the remote detection of atmospheric pollutants. *Proceedings IEEE*, 1971, **59**, 1644-663.
8. Cattrall, C.; Reagan, J.A. & Thome, K.J. Lidar aerosol ratios at 1 and 10 microns. *Proceedings SPIE*, **5086**, 2003, 112-20.
9. Ambrico, P.F.; Amodeo, A.; Girolamo P.D. & Spinelli, N. Sensitivity analysis of differential absorption lidar measurements in the mid-infrared region. *Applied Optics*, 2000, **39**, 6847-865.
10. Carlisle, C.B.; Van der Laan, J.E.; Carr, L.W.; Adam, P. & Chiaroni, J.P. CO_2 laser-based differential absorption lidar system for range resolved and long range detection of chemical vapor plumes. *Applied Optics*, 1995, **34**, 6187-201.

11. Killinger, D.K.; Menyuk, N. & Defed, W.E. Experimental comparison of hetrodyne and direct detection for pulsed differential absorption CO_2 lidar. *Applied Optics*, 1983, **22**, 682-89.
12. Menyuk, N.; Killinger, D.K. & Defeo, W.E. Laser remote sensing of hydrazine, MMH, and UDMH using a differential absorption CO_2 lidar. *Applied Optics*, 1982, **21**, 2275-286.
13. Collis, R.T.H. & Russell, P.B. Lidar measurement of particles and gases by elastic backscattering and differential absorption. *In Laser monitoring of the atmosphere*, Ch. 4, edited by Hinkley. Springer-Verlag, 1976, pp. 102-09.

Contributors



Dr S.Veerabuthiran obtained his PhD from Vikram Sarabhai Space Centre, ISRO, Trivandrum and PGDQM from Anna University, Chennai, in 2003 and 1998 respectively. He visited University of Sherbrooke, Quebec, Canada for his postdoctoral research work in 2004. He joined Laser Science and Technology Centre (LASTEC), Delhi in 2004 as Scientist C. He is working on the design and development of differential absorption lidar system for the detection of toxic agents in the atmosphere.



Dr J.P. Dudeja obtained his PhD (Physics) in 1978 from the Indian Institute of Technology Delhi, New Delhi. He has about 28 research papers to his credit in various Indian and foreign journals. He is currently working as Head, Photonics Division at the LASTEC. His areas of interest are laser physics and military applications of lasers.